

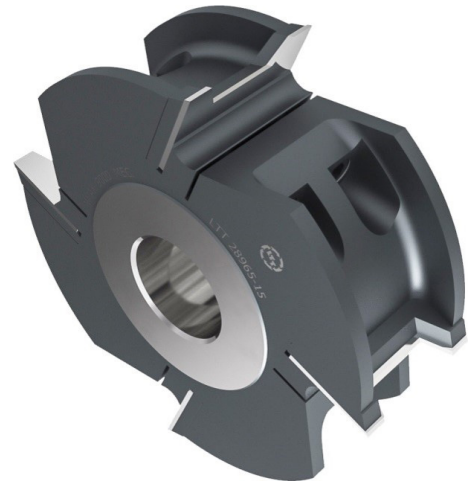

# LTT UNIVERSAL PROFILE MILLING HEAD



- Profile according to the customers needs.
- Quick delivery

## TECHNICAL DATA

ORDER-NO	D	B	Z	BORE	INSERT KNIVES	PD MAX
LTT01.001	124	40	2/3/4	30	40x28x1,5	12,0
LTT01.002	134	40	2/3/4	40	40x28x1,5	12,0
LTT01.003	144	40	2/3/4	50	40x28x1,5	12,0
LTT01.004	152	40	2/3/4	60	40x28x1,5	12,5

ORDER-NO	D	B	Z	BORE	INSERT KNIVES	PD MAX
LTT01.005	136	40	2/3/4	30	40x35x1,5	18,0
LTT01.006	134	40	2/3/4	40	40x35x1,5	18,0
LTT01.007	144	40	2/3/4	50	40x35x1,5	18,0
LTT01.008	152	40	2/3/4	60	40x35x1,5	18,5

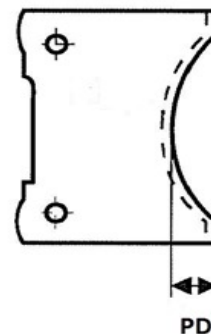

n-mx.9000

### MORE INFORMATION? PLEASE CONTACT US!

Micor Tooling, Industrigatan 10, 312 34 Laholm, Sweden  
+46 (0) 430 492 00, support@micortooling.com



# LTT SHANK CUTTER FOR CNC ROUTER



- Profile according to the customers needs.
- Quick delivery

## TECHNICAL DATA

ORDER-NO	D	B	Z	BORE	INSERT KNIVES	PD MAX
LTT01.001	124	40	2/3/4	30	40x28x1,5	12,0
LTT01.002	134	40	2/3/4	40	40x28x1,5	12,0
LTT01.003	144	40	2/3/4	50	40x28x1,5	12,0
LTT01.004	152	40	2/3/4	60	40x28x1,5	12,5

ORDER-NO	D	B	Z	BORE	INSERT KNIVES	PD MAX
LTT01.005	136	40	2/3/4	30	40x35x1,5	18,0
LTT01.006	134	40	2/3/4	40	40x35x1,5	18,0
LTT01.007	144	40	2/3/4	50	40x35x1,5	18,0
LTT01.008	152	40	2/3/4	60	40x35x1,5	18,5

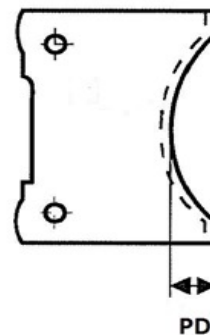

n-mx.12000

### MORE INFORMATION? PLEASE CONTACT US!

Micor Tooling, Industrigatan 10, 312 34 Laholm, Sweden  
+46 (0) 430 492 00, support@micortooling.com

**MICOR**  
TOOLING