

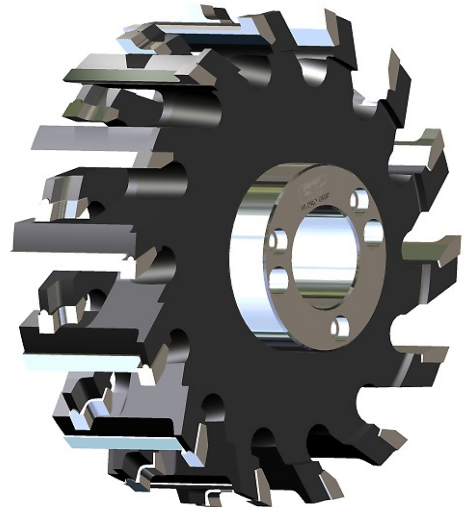

ADJUSTABLE CUTTER

- HW/HS Adjustable mm 15-50 1 set= 2 cutter



MORE INFORMATION? PLEASE CONTACT US!

Micor Tooling, Industrigatan 10, 312 34 Laholm, Sweden
+46 (0) 430 492 00, support@micortooling.com



ADJUSTABLE CUTTER



- HW/HS Adjustable mm 15-50 1 set= 2 cutter

HW (HM)

Z	D120	D140	D160	D180
4	FL012004	FL014004	FL016004	FL018004
6	-	-	FL016006	FL018006
8	-	-	FL016008	FL018008

Z	D200	D220	D230	D250
10	FL020010	FL022010	FL023010	FL025010
12	FL020012	FL022012	FL023012	FL025012
16	FL020016	FL022016	FL023016	FL025016

HS (HSS)

Z	D120	D140	D160	D180
4	FK512004	FK514004	FK516004	FK518004
6	-	-	FK516006	FK518006
8	-	-	FK516008	FK518008

Z	D200	D220	D230	D250
10	FK520010	FK522010	FK523010	FK525010
12	FK520012	FK522012	FK523012	FK525012
16	FK520016	FK522016	FK523016	FK525016

MORE INFORMATION? PLEASE CONTACT US!

Micor Tooling, Industrigatan 10, 312 34 Laholm, Sweden
+46 (0) 430 492 00, support@micortooling.com

MICOR
TOOLING



ADJUSTABLE CUTTER

- For rounding and bevelling.
- HW/HS Adjustable mm 15-50 / set= 3 cutter

1 BEVELLING OR ROUNDING

	Z	D120	D140	D160	D180
HW	2	DC012002	DC014002	-	-
HS	2	DD512002	DD514002	-	-
HW	4	DC012004	DC014004	DC016004	DC018004
HS	4	DD512004	DD514004	DD516004	DD518004
HW	6	-	-	DC016006	DC018006
HS	6	-	-	DD516006	DD518006

2 BEVELLING OR ROUNDING

	Z	D120	D140	D160	D180
HW	2	DE012002	DE014002	-	-
HS	2	DF512002	DF514002	-	-
HW	4	DE012004	DE014004	DE016004	DE018004
HS	4	DF512004	DF514004	DF516004	DF518004
HW	6	-	-	DE016006	DE018006
HS	6	-	-	DF516006	DF518006

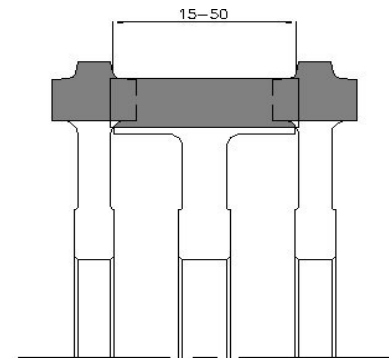
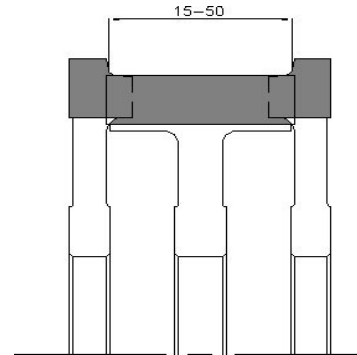

MORE INFORMATION? PLEASE CONTACT US!

Micor Tooling, Industrigatan 10, 312 34 Laholm, Sweden
 +46 (0) 430 492 00, support@micortooling.com